



www.FGWilson.com



# PG750B

## Output Ratings

Generating Set Model	PG750B
	<b>Baseload</b>
380-415V, 50 Hz	750 kVA / 600 kW

Ratings at 0.8 pf

## Definitions

### Baseload (Continuous) Rating

These ratings are applicable for supplying continuous electrical power for full load operations. There is no overload available. The ratings represent the engine performance in accordance with ISO 3046 at reference conditions equivalent to those specified in ISO 3046/1 based on the use of natural gas having a lower calorific value of 34.71MJ/m<sup>3</sup>

### Standard Reference Conditions

Note: Standard reference conditions 25°C (77°F) Air Inlet Temp, 100m (328ft) A.S.L. 30% relative humidity. All engine performance data based on the above mentioned maximum continuous ratings. Fuel consumption data at full load using gas fuel with a lower calorific value of 34.71MJ/m<sup>3</sup>

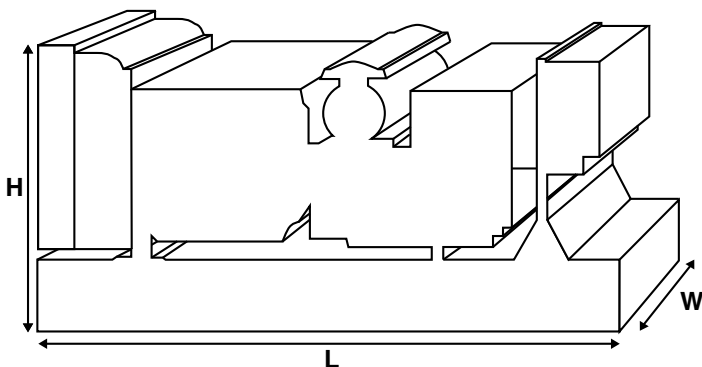

## Ratings and Performance Data

Engine Make and Model	Perkins 4012TESI
Alternator manufacturer for FG Wilson by:	Leroy Somer
Alternator Model:	LL7024P
Control Panel:	PowerWizard 2.0
Base Frame:	Heavy Duty Fabricated Steel
Circuit Breaker Type/Rating:	3 Pole MCCB
Frequency:	<b>50 Hz</b>
Engine Speed: RPM:	1500
Fuel Consumption: m <sup>3</sup> /hr (ft <sup>3</sup> /hr)	188 (6610)

## Available Options

FG Wilson offer a range of optional features to tailor our generating sets to meet your power needs. Options include:

- Upgrade to CE Certification
- A wide range of Sound Attenuated Containers
- A variety of generating set control and synchronising panels
- Additional alarms and shutdowns
- A selection of exhaust silencer noise levels

For further information on all of the standard and optional features accompanying this product please contact your local Dealer or visit: [www.FGWilson.com](http://www.FGWilson.com)

## Dimensions and Weights

Length (L) mm (in)	Width (W) mm (in)	Height (H) mm (in)	Wet kg (lb)
5585 (220)	2198 (86.5)	2601 (102)	8700 (19184)

Dry = With Lube Oil Wet = With Lube Oil and Coolant

Ratings in accordance with ISO 8528, ISO 3046, IEC 60034, BS5000 and NEMA MG-1/22. Generating set pictured may include optional accessories.

## FG Wilson has manufacturing facilities in the following locations:

Northern Ireland • Brazil • China • India • USA

With headquarters in Northern Ireland, FG Wilson operates through a Global Dealer Network. To contact your local Sales Office please visit the FG Wilson website at [www.FGWilson.com](http://www.FGWilson.com)

## Engine Technical Data

No. of Cylinders/Alignment:	8 in-line
Cycle:	V 12
Bore/Stroke: mm (in)	160 (6.3) / 190 (7.5)
Induction:	Turbocharged
Cooling Method:	Water
Governing Type:	Electronic
Governing Class:	ISO 8528 G2
Compression Ratio:	9.5:1
Displacement: l (cu.in):	45.84 (2797)
Moment of Inertia: kg m <sup>2</sup> (lb/in <sup>2</sup> )	6.04 (20639)
Engine Electrical System:	
-Voltage/Ground	24/Negative
-Battery Charger Amps	32
Weight: kg (lb)	
- Dry	4680 (10319)
- Wet	4908 (10822)

## Performance

Engine Speed: rpm	1500
Gross Engine Power: kW (hp)	632 (847)
BMEP: kPa (psi)	1104 (160)

## Fuel Systems

Permitted Fuel:	Natural gas with lower calorific value of 34.7 MJ/m <sup>3</sup> and minimum methane number of 65
-----------------	---

Fuel consumption varies widely within each gas type stated. This is because these gases are available (naturally or produced) with variances in their physical properties.

## Air Systems

Air Filter Type:	Replaceable Element
Combustion Air Flow: m <sup>3</sup> /min (cfm)	52.0 (1836)
Max. Combustion Air Intake Restriction: kPa (in H <sub>2</sub> O)	3.8 (15.2)
Radiator Cooling Airflow: m <sup>3</sup> /min (cfm)	887 (31320)
External Restriction to Cooling Airflow: Pa (in Wg)	125 (0.5)

## Cooling System

Cooling System Capacity: l (US gal)	135 (35.7)
Water Pump Type:	Gear Driven
Heat Rejected to Water & Lube Oil: kW (Btu/min)	525 (29858)
Heat Radiation to Room: kW (Btu/min)	47.0 (2673)
Heat Rejected to Charge Cooler kW (Btu/min)	122 (6938)
Radiator Fan Load:	Electric

Cooling system designed to operate in ambient conditions up to 40°C (104°F). Contact your local FG Wilson Dealer for power ratings at specific site conditions.

## Lubrication System

Oil Filter Type:	Spin-On, Full Flow
Total Oil Capacity: l (US gal)	178 (47.0)
Oil Pan: l (US gal)	159 (42.0)
Oil Type:	API-CF4
Oil Cooling Method:	Water

## Exhaust System

Silencer Type:	Level 1
Silencer Model & Qty:	SD150
Pressure Drop Across Silencer System: kPa (in Hg)	1.25 (0.37)
Silencer Noise Reduction Level: dBA	18.0
Max. Allowable Back Pressure: kPa (in Hg)	5,3 (1,57)
Exhaust Gas Flow: m <sup>3</sup> /min (cfm)	127 (4484)
Exhaust Gas Temperature: °C (°F):	424 (795)
Heat Rejected to Exhaust System: kW (Btu/min)	457 (25991)

## Alternator Physical Data

Manufactured for FG Wilson by:	Leroy Somer
Model:	LL7024P
No. of Bearings:	Single
Insulation Class:	H
Winding Pitch Code:	2/3 (No. 6)
Wires:	12
Ingress Protection Rating:	IP23
Excitation System:	Shunt
AVR Model:	R450

## Alternator Operating Data

Overspeed: RPM	2250
Voltage Regulation (steady state):	+/- 0.5
Wave Form NEMA = TIF:	<50
Wave Form IEC = THF:	<2%
Total Harmonic Content LL/LN:	<4%
Radio Interference:	Suppression is in line with European Standard EN61000
Radiant Heat: kW (Btu/min)	50 Hz: 36.0 (2017)

## Alternator Performance Data:

Data Item	415/240V	400/230	380/220
<b>Motor Starting</b>			
Capability* kVA	2613	2446	2228
Short Circuit Capacity** %	300	300	300
<b>Reactances:</b>			
Per Unit			
Xd	2.58	2.77	3.07
X'd	0.12	0.13	0.15
X''d	0.098	0.105	0.116

Reactances shown are applicable to baseload ratings

\* Based on 30% voltage dip at 0.6 power factor.

\*\* With optional Permanent Magnet generator or AREP excitation.

## Voltage Technical Data

	PG750B Baseload	
	kVA	kW
415/240	750	600
400/230	750	600
380/220	750	600

## General Information

### Documentation

A full set of operation and maintenance manuals and circuit wiring diagrams, and commissioning/fault finding instruction leaflets.

### Generating Set Standards

The equipment meets the following standards: BS5000, ISO 8528, ISO 3046, IEC 60034, NEMA MG-1.22.  
FG Wilson is a fully accredited ISO 9001 company.

### Warranty

All equipment carries full manufacturer's warranty. Extended warranty terms available. For details on warranty cover please contact your local dealer, or visit our website: [www.FGWilson.com](http://www.FGWilson.com)

### Dealer Contact Details:

### FG Wilson has manufacturing facilities in the following locations:

Northern Ireland • Brazil • China • India • USA

With headquarters in Northern Ireland, FG Wilson operates through a Global Dealer Network.  
To contact your local Sales Office please visit the FG Wilson website at [www.FGWilson.com](http://www.FGWilson.com)