



www.FGWilson.com



PG1250B2

Output Ratings

Generating Set Model	PG1250B2
	Baseload
380-415V, 50 Hz	1250 kVA / 1000 kW

Ratings at 0.8 pf

Definitions

Baseload (Continuous) Rating

These ratings are applicable for supplying continuous electrical power for full load operations. There is no overload available. The ratings represent the engine performance in accordance with ISO 3046 at reference conditions equivalent to those specified in ISO 3046/1 based on the use of natural gas having a lower calorific value of 34.71MJ/m³.

Standard Reference Conditions

Note: Standard reference conditions 25°C (77°F) Air Inlet Temp, 100m (328ft) A.S.L. 30% relative humidity. All engine performance data based on the above mentioned maximum continuous ratings. Fuel consumption data at full load using gas fuel with a lower calorific value of 34.71MJ/m³.

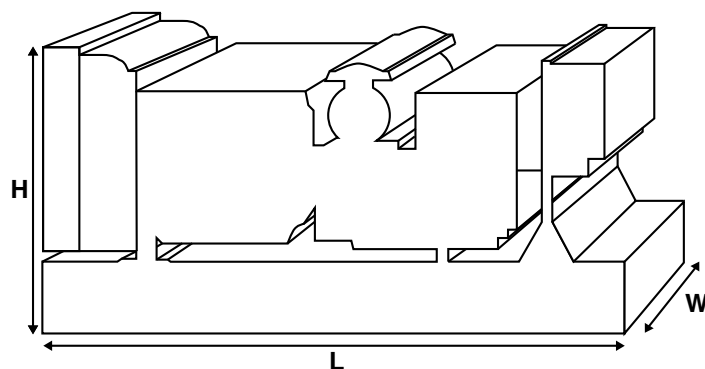

Ratings and Performance Data

Engine Make and Model	Perkins 4016-61TRS2
Alternator manufacturer for FG Wilson by:	Leroy Somer
Alternator Model:	LL8224P
Control Panel:	PowerWizard 2.0
Base Frame:	Heavy Duty Fabricated Steel
Circuit Breaker Type/Rating:	2000A ACB
Frequency:	50 Hz
Engine Speed: RPM:	1500
Fuel Consumption: m ³ /hr (ft ³ /hr)	273 (9599)

Available Options

FG Wilson offer a range of optional features to tailor our generating sets to meet your power needs. Options include:

- Upgrade to CE Certification
- A wide range of Sound Attenuated Containers
- A variety of generating set control and synchronising panels
- Additional alarms and shutdowns
- A selection of exhaust silencer noise levels

For further information on all of the standard and optional features accompanying this product please contact your local Dealer or visit: www.FGWilson.com

Dimensions and Weights

Length (L) mm (in)	Width (W) mm (in)	Height (H) mm (in)	Wet kg (lb)
6340 (249.6)	2100 (82.7)	3370 (132.7)	14320 (31570)

Dry = With Lube Oil Wet = With Lube Oil and Coolant

Ratings in accordance with ISO 8528, ISO 3046, IEC 60034, BS5000 and NEMA MG-1/22. Generating set pictured may include optional accessories.

FG Wilson has manufacturing facilities in the following locations:

Northern Ireland • Brazil • China • India • USA

With headquarters in Northern Ireland, FG Wilson operates through a Global Dealer Network. To contact your local Sales Office please visit the FG Wilson website at www.FGWilson.com

Engine Technical Data

No. of Cylinders/Alignment:	16 V
Cycle:	4 Stroke
Bore/Stroke: mm (in)	160 (6.3) / 190 (7.5)
Induction:	Turbocharged
Cooling Method:	Water
Governing Type:	Electronic
Governing Class:	ISO 8528 G3
Compression Ratio:	12.0:1
Displacement: l (cu.in):	61.123 (3730)
Moment of Inertia: kg m ² (lb/in ²)	8.65 (29558)
Engine Electrical System:	
-Voltage/Ground	24/Insulated Return
-Battery Charger	28 Amps at 20°C
Weight: kg (lb)	- Dry 5820 (12831) - Wet 6158 (13576)

Performance

Engine Speed: rpm	1500
Gross Engine Power: kW (hp)	1042 (1397)
BMEP: kPa (psi)	1364 (198)

Fuel Systems

Fuel Filter Type:	Non woven PP fabric: 50 micron
Permitted Fuel:	Natural gas with lower calorific value of 34.7MJ/m ³ and minimum methane number of 75. (Alternative gas types can be used: contact Power Solutions.)

Fuel consumption varies widely within each gas type stated. This is because these gases are available (naturally or produced) with variances in their physical properties.

Air Systems

Air Filter Type:	Dry Replaceable Element
Combustion Air Flow: m ³ /min (cfm)	79.7 (2815)
Max. Combustion Air Intake Restriction: kPa (in H ₂ O)	3.73 (15.0)

Cooling System

Cooling System Capacity: l (US gal)	330 (87.2)
Water Pump Type:	Gear Driven
Heat Rejected to Water & Lube Oil: kW (Btu/min)	653 (37135)
Heat Radiation to Room: kW (Btu/min)	132 (7507)
Radiator Fan Load:	60 (80.4)

Designed to operate in ambient conditions up to 50°C (122°F).
Contact your local FG Wilson Dealer for power ratings at specific site conditions.

Lubrication System

Oil Filter Type:	Spin-On, Full Flow
Total Oil Capacity: l (US gal)	286 (75.6)
Oil Pan: l (US gal)	257 (67.9)
Oil Type:	See Perkins Service Bulletin 48
Oil Cooling Method:	Water

Exhaust System

Silencer Type:	Optional
Pressure Drop Across Silencer System: kPa (in Hg)	System Dependant
Max. Allowable Back Pressure: kPa (in Hg)	3.9 (1.16)
Exhaust Gas Flow: m ³ /min (cfm)	211 (7435)
Exhaust Gas Temperature: °C (°F)	46.8 (874)
Heat Rejected to Exhaust System: kW (Btu/min)	803 (45666)

Alternator Physical Data

Manufactured for FG Wilson by:	Leroy Somer
Model:	LL8224P
No. of Bearings:	Single
Insulation Class:	H
Winding Pitch Code:	2/3 (No. 6S)
Wires:	6
Ingress Protection Rating:	IP23
Excitation System:	AREP / PMG
AVR Model:	R449

Alternator Operating Data

Overspeed: RPM	2250
Voltage Regulation (steady state):	+/- 0.5
Wave Form NEMA = TIF:	<50
Wave Form IEC = THF:	<2%
Total Harmonic Content LL/LN:	<3.5%
Radio Interference:	Suppression is in line with European Standard EN61000
Radiant Heat: kW (Btu/min)	50 Hz: 45.8 (2605)

Alternator Performance Data:

Data Item	415/240V	400/230	380/220
Motor Starting Capability* kVA	4592	4282	3883
Short Circuit Capacity** %	300	300	300
Reactances:			
Per Unit			
X_d	2.560	2.760	3.060
X'_d	0.160	0.172	0.190
X''_d	0.089	0.096	0.106

Reactances shown are applicable to baseload ratings

* Based on 30% voltage dip at 0.4 power factor.

** With optional Permanent Magnet generator or AREP excitation.

Voltage Technical Data

	PG1250B2 Baseload	
	kVA	kW
415/240	1250	1000
400/230	1250	1000
380/220	1250	1000

General Information

Documentation

A full set of operation and maintenance manuals and circuit wiring diagrams.

Generating Set Standards

The equipment meets the following standards: BS5000, ISO 8528, ISO 3046, IEC 60034, NEMA MG-1.22.
FG Wilson is a fully accredited ISO 9001 company.

Warranty

All equipment carries full manufacturer's warranty. Extended warranty terms available. For details on warranty cover please contact your local dealer, or visit our website: www.FGWilson.com

Dealer Contact Details:

FG Wilson has manufacturing facilities in the following locations:

Northern Ireland • Brazil • China • India • USA

With headquarters in Northern Ireland, FG Wilson operates through a Global Dealer Network.
To contact your local Sales Office please visit the FG Wilson website at www.FGWilson.com