



4000 Series EGi

4016-E61TRS

Spark Ignited Gas Engine

1042 kWm at 1500 rev/min

Efficient power

The modern design of the very latest developments in combustion and engineering techniques, to give world beating, fuel efficiencies, economical whole life costs and reliability.

Clean, smooth power

Extensive research in combustion, air smell and noise/vibration/harshness have resulted in a smooth, quiet engine. This, combined with the emissions performance makes the 4016-E61TRS more environmentally acceptable in these days of increased concern.

Reliable power

Extended durability and attention to reduced servicing with extended component life add to the benefit of reduced whole life cost. Total after-sales service, backed by a network of Perkins Gas Partners with dedicated expertise in service and maintenance of gas engines.

Options

The 4016-E61TRS spark ignited gas engine can be supplied to suit customer requirements as a Gas Electro Unit for power generation or Cogen unit specification for combined heat and power operation.

Designed to meet the future demands of the market for clean, efficient gas fuelled engines for the power generation industry, the Perkins 4016-E61TRS 16-cylinder spark ignition gas engine offers high performance, dependability and reliability while meeting the increasingly stringent emission requirements of the market.

The 4016-E61TRS is a turbocharged and air-to-water charged cooled 16-cylinder vee-form engine designed for operation on natural gas. Particular emphasis on efficiency and emission control together with durability, reliability and exceptional thermal efficiency and reduced whole life costs, make selection of the Perkins 4016-E61TRS engine the prime choice at a nominal 1000 kW_e.

Engine Speed (rev/min)	Type of Operation	Gross Engine Power	
		kW _e	kW _m
1500	Continuous Operation Power	1008	1042

The above ratings represent the engine performance capabilities specified in ISO 8528/1, BS5514/1.

Electrical ratings are based on average alternator efficiency at unity power factor, based on Natural Gas having a lower calorific value of 34.71 MJ/m³.

Please consult your local Perkins distributor or Perkins distributor or Perkins Engines Company Limited for derating for ambient conditions or for use of gaseous fuels other than that specified above.

Rating Definitions

Continuous Operation Power: A 'true' Baseload rating as defined in ISO 8528 as 'COP'.

4000 Series EGi

4016-E61TRS

Standard Specification

Core engine

- High grade cast iron featuring integral crankcase inspection doors
- Wet type liners in centrifugal cast iron, plateau honed for quick ring bedding and reduced oil consumption
- Forged steel crankshaft
- Forged camshaft – carburised hardened
- High grade cast iron individual cylinder heads, each with four valves per cylinder
- Crankshaft driven gear train for camshaft
- Aluminium alloy piston with advanced bowl design. Three ring pack, gallery (oil) cooled
- Slit cap connecting rods, forged steel with multi-bolt fixing – shot peened

Gas/Ignition system

- Air/Fuel mixer with Woodward Tecjet gas injection valve control system; automatic adjustment according to fuel gas characteristics
- Metal braided flexible gas connection
- Individual cylinder ignition coils mounted direct to the spark plugs

Lubrication system

- Gear driven lubricating oil pump, externally mounted
- Spin on, canister type replaceable lubricating oil filters
- Shell and tube type oil coolers, jacket water cooled
- Crankcase closed circuit ventilation system

Cooling system

- Pressurised fresh water jacket water cooling system
- Two-stage air to water charge cooler, jacket/secondary water cooled

Air intake system

- Paper element air filter complete with restriction indicator
- Exhaust gas driven turbocharger

Exhaust system

- Dry cast iron exhaust manifolds with heat shields
- Horizontal exhaust outlet

Engine management system

- Full electronic management system, governing to ISO 8528 Part 5 Class G2 standard
- Engine protection system for high/low coolant temperature and low oil pressure, overspeed, misfire and knock protection
- Customer communication module

Electrical system

- 24 volt electric starter motors

Drive system

- Cast iron flywheel housing SAE 00 and flywheel SAE J620 Size 18
- Viscous type torsional vibration damper

Engine mountings

- Engine supports: front and rear feet mounted off the crankcase

Painting

- Commercial primer finish

Packing/Preservation

- All engines are preserved after test running, shrink wrapping and suitable for containerised shipment

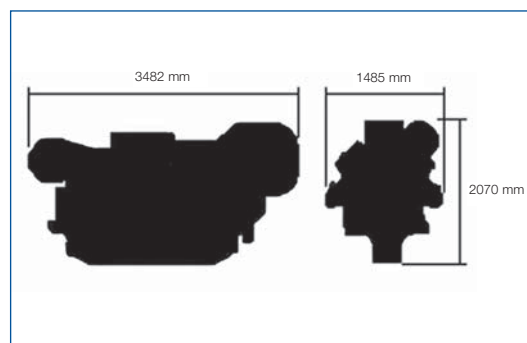

General Data

Number of cylinders	16
Cylinder arrangement	60° Vee
Cycle	4 stroke
Induction system	Turbocharged Two-stage charge cooled
Combustion system	Spark ignition
Cooling system	Water-cooled
Bore and stroke	160 x 190 mm
Displacement	61.12 litres
Compression ratio	12:1
Direction of rotation	Anti-clockwise, viewed on flywheel
Total lubrication system capacity	286 litres
Total coolant capacity	95 litres
Length	3482 mm
Width	1485 mm
Height	2070 mm
Dry weight	5600 kg

Final weight and dimensions will depend on completed specification

	Fuel Consumption (kJ/kWs)	
	TALuft	1/2TALuft
100% of COP	2.47	2.53



Perkins Engines Company Limited

Peterborough PE1 5NA
United Kingdom
Telephone +44 (0)1733 583000
Fax +44 (0)1733 582240
www.perkins.com

Distributed by