

# 4000 Series

## 4008TESI

### Spark Ignited Gas Engine

400 kWm at 1200 rpm  
430 kWm at 1500 rpm



Developed from a proven engine range that offers superior performance and reliability, the 4008TESI is designed to meet the future demands of the market for clean, efficient gas fuelled engines for the power generation industry.

The 4008TESI 8-cylinder spark ignition gas engine offers high performance, dependability and reliability while meeting the increasingly stringent emission requirements of the market.

The 4008TESI is a turbocharged, air to water charge cooled 8 cylinder inline engine designed for operation on a wide range of methane based gases. The premium features and design provide economic and durable operation, whilst offering improved emissions. The overall performance and reliability characteristics make this the prime choice for today's power generation industry.

#### Economic power

- Utilises advanced combustion technology to deliver durable and reliable power.
- High commonality of components with other engines in the 4000 Series family for reduced stocking levels.
- Individual 4 valve cylinder heads with matched piston for efficient combustion.

#### Reliable power

- Developed and tested using the latest engineering techniques.
- Piston temperatures controlled by an advanced gallery jet cooling system.
- Extended durability and component life reduces service intervals and cost of ownership.

#### Compact, clean and efficient power

- High power to weight ratio combined with compact size provide optimum power density for ease of transportation and installation.
- Designed to provide excellent service access for ease of maintenance.
- Engines to comply with major international standards.
- All engines in the 4000 Series family are capable of meeting the requirements of TA Luft (1986).

Engine Speed (rev/min)	Type of Operation	Typical Generator Output (Gross)		Gross Engine Power	
		kWe		kWm	
1200	Continuous Operating Power	384		400	
1500	Continuous Operating Power	425		430	

The above ratings represent the engine performance capabilities to conditions specified in ISO 8528/1, ISO 3046/1:1986, BS 5514/1. Derating may be required for conditions outside these; consult Perkins Engines Company Limited.

Generator powers are typical and are based on an average alternator efficiency and a power factor (cos.  $\theta$ ) of 1. Fuel specification: Natural gas having a Lower Calorific Value of 34.71 MJ/m<sup>3</sup>.

#### Rating Definitions

Continuous Operating Power: Power available for true Base load, rating as defined in ISO 8528/1, BS 5514/1 – Overload permitted only on Low Compression models.

# 4000 Series

## 4008TESI

### Electronit/Cogen Specification

#### Air inlet and exhaust

- Mounted air filter – replaceable cartridge type
- Jacket water-cooled exhaust manifolds with high efficiency turbocharger, with outlet and counter flange

#### Governing, gas and ignition system

- Air/Fuel mixer with zero pressure regulator and mixture adjustment screw
- Metal braided flexible gas connection
- Altronic 800 'C' Series ignition system
- Individual cylinder ignition coils
- Electronic governing, governing to ISO 8528-5 class G2

#### Lubrication system

- Gear driven, externally mounted lubricating oil pump
- Wet sump with filler and dipstick
- Full-flow replaceable canister type oil filters
- Jacket water cooled shell and tube oil cooler/stabiliser
- Closed circuit crankcase ventilation system – natural gases only

#### Cooling system

- Pressurised jacket water cooling system, with gear-driven jacket water circulating pump and pipe work – supply on Electronit only
- Air to water charge cooler, pipe work supply on Electronit only
- Jacket water thermostatic control supply on Electronit only

#### Electrical equipment

- 24 volt starter motor
- 24 volt 70 amp battery charging alternator with integral voltage regulator and activating switch – supply on Electronit only
- High coolant temperature/low oil pressure switch
- High manifold pressure switch
- Flywheel and Housing
- High inertia flywheel to SAE J620 Size 14
- SAE 'O' flywheel housing

#### Mountings

Front and rear engine mounting support

#### Literature

User's Handbook and Parts Manual

#### Optional Equipment

- 220 volt/240 volt thermostatically controlled immersion heater
- Digital knock detection
- Three way thermostatic valve for charge cooler cooling circuit
- Mechanically driven water pump for charge cooler circuit
- Auto synchronising/load share modules
- Cooling systems on application
- Exhaust monitoring module(s)
- Tool kit
- Additional manuals

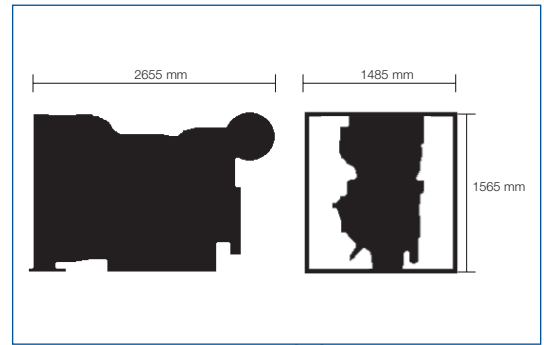

### General Data

Number of cylinder	8
Cylinder arrangement	Vertical in-line
Cycle	4 stroke
Induction system	Turbocharged and air-to-air charge cooled
Combustion system	Spark ignited
Cooling system	Water cooled
Bore and stroke	160 x 180 mm
Displacement	Body text
Compression ratio	9.5:1 – (LC) 11.5:1 – (HC) high compression
Direction of rotation	Anti-clockwise viewed on flywheel
Total lubrication system capacity	165.5 litres
Total coolant capacity	48 litres
Length	2655 mm
Width	1485 mm
Height	1565 mm
Dry weight	3350 kg

Final weight and dimensions will depend on completed specification

Engine Speed	Fuel Consumption (kJ/kWs*)	
	1200 rev/min	1500 rev/min
4008TESI 200LC 100% of COP	–	2.82
4008TESI 140LC# 100% of COP	2.83	2.83
4008TESI 140HC# 100% of COP	–	2.69

# Fuel consumption figures are for TA Luft compliant engines at ISO 8528/1.  
\* Cogen specification engine.



### Perkins Engines Company Limited

Peterborough PE1 5NA  
United Kingdom  
Telephone +44 (0)1733 583000  
Fax +44 (0)1733 582240  
[www.perkins.com](http://www.perkins.com)

All information in this document is substantially correct at time of printing and may be altered subsequently  
Publication No. 2185/10/05 Produced in England ©2005 Perkins Engines Company Limited

Distributed by