



www.FGWilson.com

P150-2



Image for illustration purposes only.

Output Ratings

Generating Set Model	Prime*	Standby*
380-415V,50Hz	135.0 kVA / 108.0 kW - / -	150.0 kVA / 120.0 kW - / -

Ratings at 0.8 power factor.

Prime Rating

These ratings are applicable for supplying continuous electrical power (at variable load) in lieu of commercially purchased power. There is no limitation to the annual hours of operation and this model can supply 10% overload power for 1 hour in 12 hours.

Standby Rating

These ratings are applicable for supplying continuous electrical power (at variable load) in the event of a utility power failure. No overload is permitted on these ratings. The alternator on this model is peak continuous rated (as defined in ISO 8528-3).

Standard Reference Conditions

Note: Standard reference conditions 25°C (77°F) Air Inlet Temp, 100m (328 ft) A.S.L. 30% relative humidity.
Fuel consumption data at full load with diesel fuel with specific gravity of 0.85 and conforming to BS2869: 1998, Class A2.

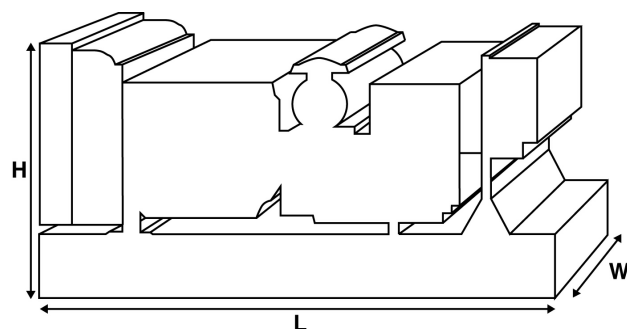

Ratings and Performance Data

Engine Make & Model:	Perkins 1106C-E66TAG2	
Alternator manufactured for FG Wilson by:	Leroy Somer	
Alternator Model:	LL3014F	
Control Panel:	PowerWizard 1.1	
Base Frame:	Fbc2 - (08Hr)	
Circuit Breaker Type:	3 Pole MCCB	
Frequency:	50 Hz	60 Hz
Engine Speed: RPM	1500	-
Fuel Tank Capacity:	349 (92.2)	
litres (US gal)		
Fuel Consumption: l/hr (US gal/hr)		
(100% Load)	Prime	30.7 (8.1)
	Standby	33.2 (8.8)
		-
		-

Available Options

- CE Certification
- Sound Attenuated EC Enclosures
- Control Panel Upgrades
- Range of Silencers
- Range of Remote Fuel Systems
- Range of Alarms and Shutdowns

Dimensions and Weights

Length (L)	Width (W)	Height (H)	Dry	Wet
mm (in)	mm (in)	mm (in)	kg (lb)	kg (lb)
2500 (98.4)	1120 (44.1)	1528 (60.2)	1659 (3657)	1680 (3704)
Dry = With Lube Oil		Wet = With Lube Oil and Coolant		

Ratings in accordance with ISO 8528, ISO 3046, IEC 60034, BS5000 and NEMA MG-1/22. Generating set pictured may include optional accessories.

FG Wilson has manufacturing facilities in the following locations:

Northern Ireland • Brazil • China • India • USA

With headquarters in Northern Ireland, FG Wilson operates through a Global Dealer Network.

To contact your local Sales Office please visit the FG Wilson website at www.FGWilson.com

Engine Technical Data

No. of Cylinders / Alignment:	6 / In Line	
Cycle:	4 Stroke	
Bore / Stroke: mm (in)	105.0 (4.1)/127.0 (5.0)	
Induction:	Turbocharged	
Cooling Method:	Water	
Governing Type:	Electronic	
Governing Class:	ISO 8528 G2	
Compression Ratio:	16.2:1	
Displacement: l (cu. in)	6.6 (402.8)	
Moment of Inertia: kg m ² (lb/in ²)	1.61 (5502)	
Engine Electrical System:		
- Voltage / Ground	12/Negative	
- Battery Charger Amps	100	
Weight: kg (lb)	- Dry	788 (1737)
	- Wet	822 (1812)

Performance

	50 Hz	60 Hz
Engine Speed: rpm	1500	-
Gross Engine Power: kW (hp)		
- Prime	121.6 (163.0)	-
- Standby	137.4 (184.0)	-
BMEP: kPa (psi)		
- Prime	1474.0 (213.8)	-
- Standby	1666.0 (241.6)	-

Fuel System

Fuel Filter Type:	Replaceable Element			
Recommended Fuel:	Class A2 Diesel			
Fuel Consumption: l/hr (US gal/hr)				
	110%	100%	75%	50%
Prime	Load	Load	Load	Load
50 Hz	33.2 (8.8)	30.7 (8.1)	24.2 (6.4)	16.7 (4.4)
60 Hz	-	-	-	-
	110%	100%	75%	50%
Standby	Load	Load	Load	Load
50 Hz	33.2 (8.8)	26.4 (7.0)	18.5 (4.9)	
60 Hz	-	-	-	

(Based on diesel fuel with a specific gravity of 0.84 and conforming to BS2869, Class A2)

Air Systems

	50 Hz	60 Hz
Air Filter Type:	Paper Element	
Combustion Air Flow: m ³ /min (cfm)		
- Prime	8.9 (314)	-
- Standby	9.4 (332)	-
Max. Combustion Air Intake Restriction: kPa (in H ₂ O)	8.0 (32.1)	-

Cooling System

	50 Hz	60 Hz
Cooling System Capacity: l (US gal)	21.0 (5.5)	-
Water Pump Type:	Centrifugal	
Heat Rejected to Water & Lube Oil:		
kW (Btu/min)	- Prime	62.8 (3571)
	- Standby	66.5 (3782)
Heat Radiation to Room: Heat radiated from engine and alternator		
kW (Btu/min)	- Prime	9.7 (552)
	- Standby	10.4 (591)
Radiator Fan Load: kW (hp)	4.5 (6.0)	-
Radiator Cooling Airflow: m ³ /min (cfm)	241.2 (8518)	-
External Restriction to Cooling Airflow: Pa (in H ₂ O)		
	120 (0.5)	-

Cooling system designed to operate in ambient conditions up to 50°C (122°F). Contact your local FG Wilson Dealer for power ratings at specific site conditions.

Lubrication System

Oil Filter Type:	Spin-On, Full Flow	
Total Oil Capacity: l (US gal)	16.5 (4.4)	
Oil Pan: l (US gal)	15.5 (4.1)	
Oil Type:	API CH4 / CI4 15W-40	
Oil Cooling Method:	Water	

Exhaust System

	50 Hz	60 Hz
Silencer Type:	Industrial	
Silencer Model & Quantity:	SD100 (1)	
Pressure Drop Across Silencer System: kPa (in Hg)		
	0.45 (0.133)	-
Silencer Noise Reduction Level: dB	19	-
Maximum Allowable Back Pressure: kPa (in Hg)		
	10.0 (3.0)	-
Exhaust Gas Flow: m ³ /min (cfm)		
- Prime	23.1 (816)	-
- Standby	24.4 (862)	-
Exhaust Gas Temperature: °C (°F)		
- Prime	430 (806)	-
- Standby	441 (826)	-

Documentation

A full set of operation and maintenance manuals and circuit wiring diagrams.

Generating Set Standards

The equipment meets the following standards: BS5000, ISO 8528, ISO 3046, IEC 60034, NEMA MG-1.22.

FG Wilson is a fully accredited ISO 9001 company.

EU Stage II Emissions Compliant.

Warranty

All prime equipment carries a one year manufacturer's warranty. Standby equipment, limited to 500 running hours per year, has a two year manufacturer's warranty. For details on warranty cover please contact your local Dealer, or visit our website: FGWilson.com.

Dealer contact details:

FG Wilson has manufacturing facilities in the following locations:

Northern Ireland • Brazil • China • India • USA

With headquarters in Northern Ireland, FG Wilson operates through a Global Dealer Network.

To contact your local Sales Office please visit the FG Wilson website at www.FGWilson.com